

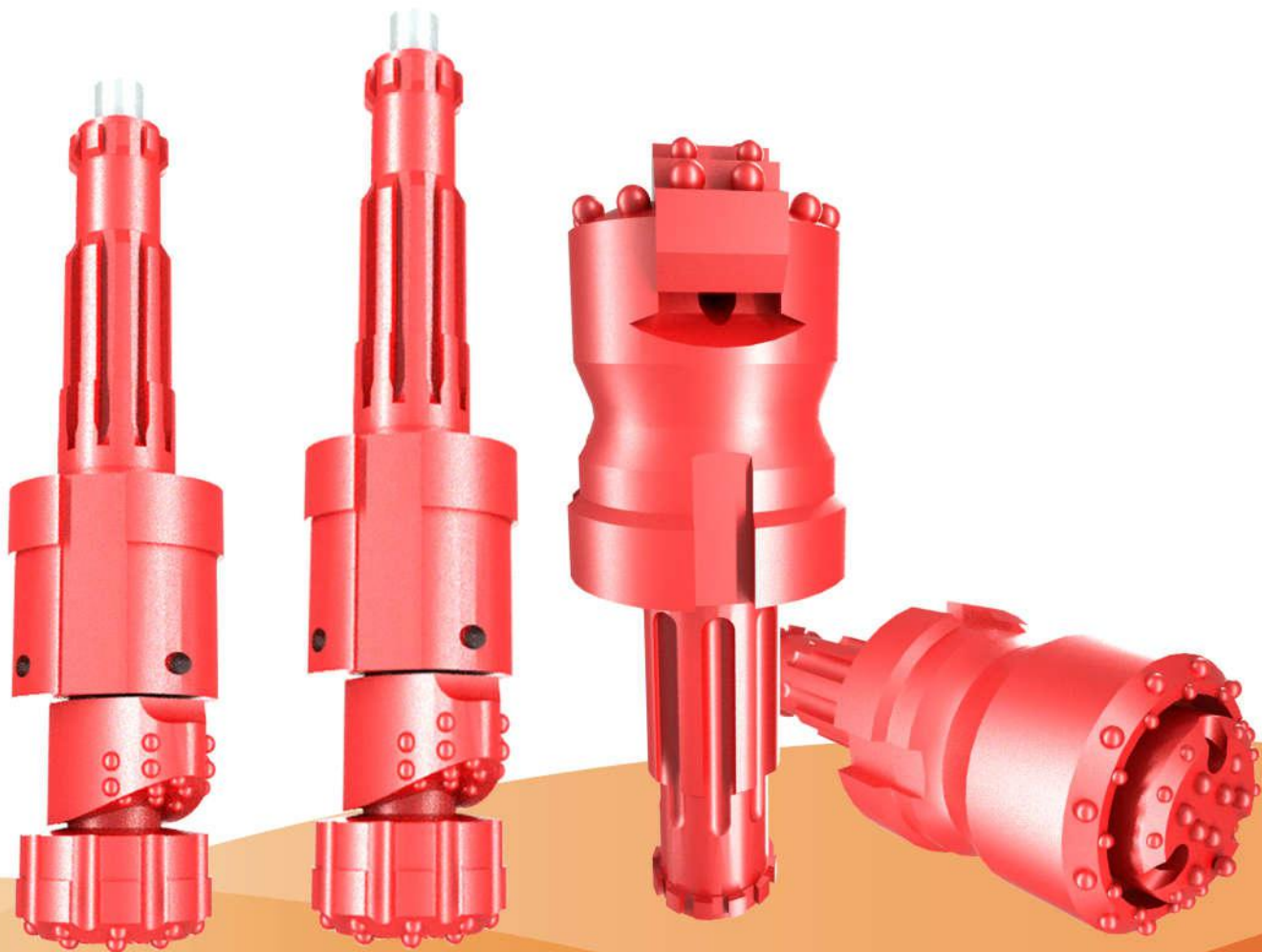

Overburden Drilling System

MAXDRILL ROCK TOOLS CO.,LTD



CONTENTS

Guide of Product Code	03
Concentric Casing System	05
With Rings	06
With Wings	13
With Blocks	18
Eccentric Casing System	24
With Three Pieces	25
Casing Tube	30
Casing Shoe Threaded Model	32
Casing Shoe Welding Model	33
Drill Pipe	34
Double Casing Drilling Tools	37

Guide of Product Code

Concentric System (i.e. MDC76/7RPT-01)

MD	C	76	7	R	P	T	01
Maxdrill	Concentric	O.D. Of Casing Tube	Thickness	R:With Ring W:With Wing B:With Block	R:Retrievable P:Permanent	Connect with Thread	01-Tophammer 02-DTH Hammer

Casing Tube (i.e. M108/7-15-S-01)

M	108	7	15	S	01
Maxdrill	O.D. Of Casing Tube	Thickness	Length	Thread: S-Square Thread C-Circular Thread	01-Casing Tube 02-Tool Joint

Casing Shoe (i.e. MST 114/6.5-S)

M	S	T	114	6.5	S
Maxdrill	Shoe	Type of Connection T-Threaded W-Welding	O.D. Of Casing Tube	Thickness	Thread S-Square Thread C-Circular Thread

Drill Pipe (i.e. M76/6.5-30-01)

M	DW	76	6.5	30	01/02/03/04/05/06/07/08
Maxdrill	Double Wall Drill Pipe	Max. O.D. of Drill Pipe	Thickness	Length	Thread: 01-API 2 3/8 REG 02-API 3 1/2 REG 03-API 4 1/2 REG 04-NC26 05-NC31 06-NC35 07-NC38 08-NC50

Concentric Casing System

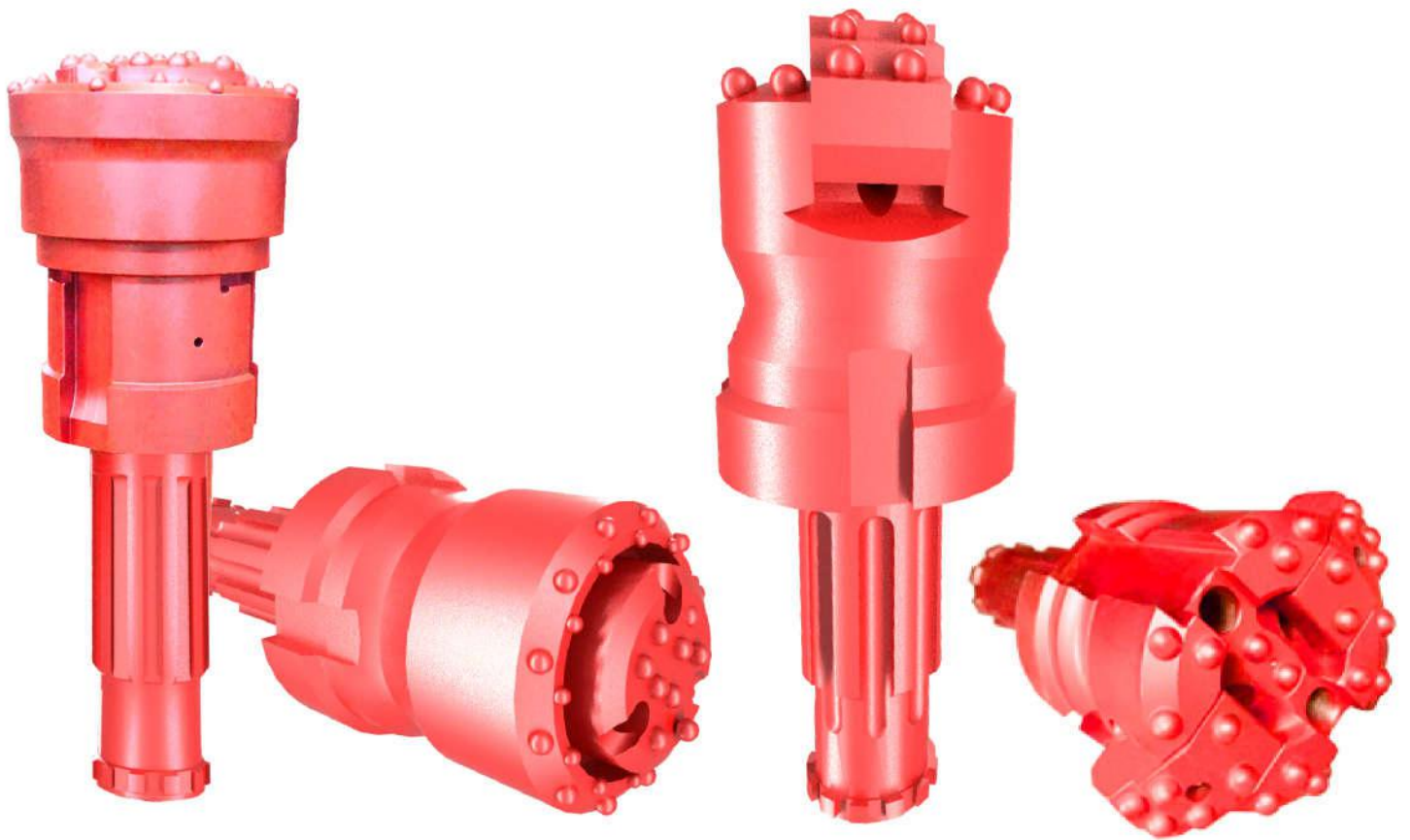

With Rings



Drilling through formations with loose, unconsolidated material always comes with problems such as the bore hole caving in or collapsing. How to avoid these problems?

With years of field practice and research, Maxdrill has developed its Concentric casing system with ring bit for the widest applications, including formations which Eccentric and Concentric casing system with blocks are used for, also for those with boulders and cavities. With efficient penetration, the system is up to casing 100 meters, and can also be used for foundation piling.

Application Range

Applied to overburden formations with complex topographic and geological conditions, such as gravel, fissured formation, boulder, landfill of construction refuse, etc.

Drills at any angle;

Good straightness of borehole;

Maximum depth of borehole can reach 150 meters.

Structural Advantages

- ◆ **Straightness:** ensures the straightness of borehole in different topographic and geological conditions.
- ◆ **Adaptability:** ensures penetration efficiency in complex topographic and geological conditions, such as gravel and landfill of construction refuse.
- ◆ **Lower torque:** the system torque is less than eccentric casing system.
- ◆ **Easy to unlock an re-rock:** easy to re-rock after unlock.
- ◆ **Drilling at any angle:** concentric casing system can drill under horizontal, vertical and inclined conditions.
- ◆ **Environmental:** better than eccentric casing system, because of its advantages of drilling smoothly, small vibration and low noise, it is more suitable for construction in urban areas.

Component Parts



Operation Schematic Figure

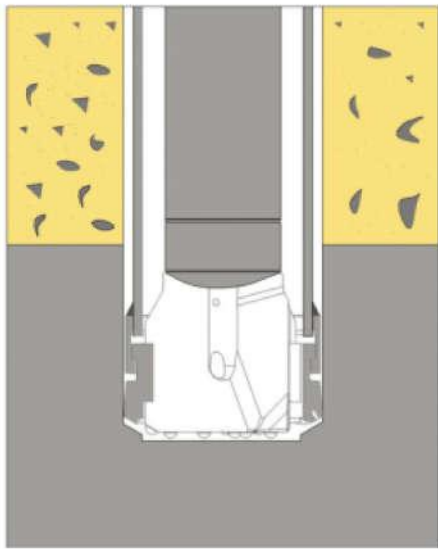

The drilling in overburden formation is finished.

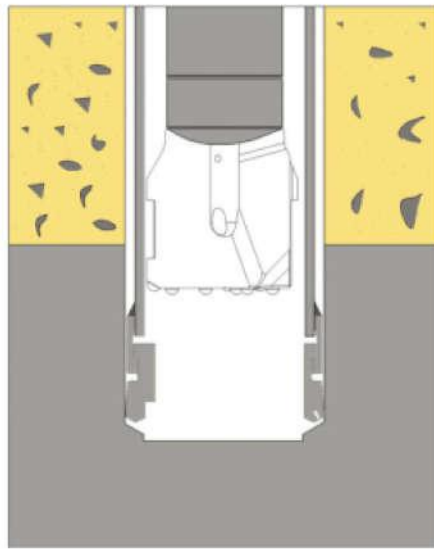

Reverse rotation of the hammer and pull the pilot bit out from the hole.

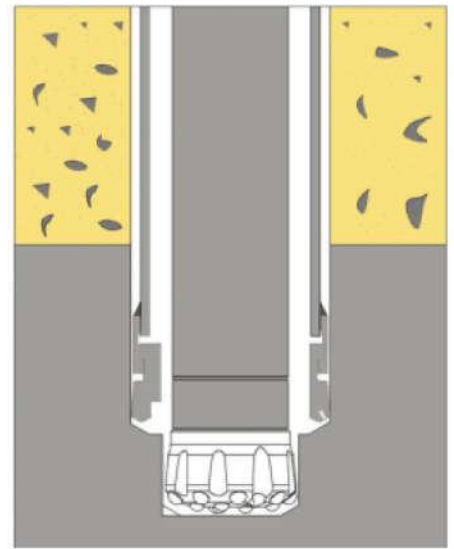

Replace the pilot bit with normal bit to continue drilling down.

Related Parts List

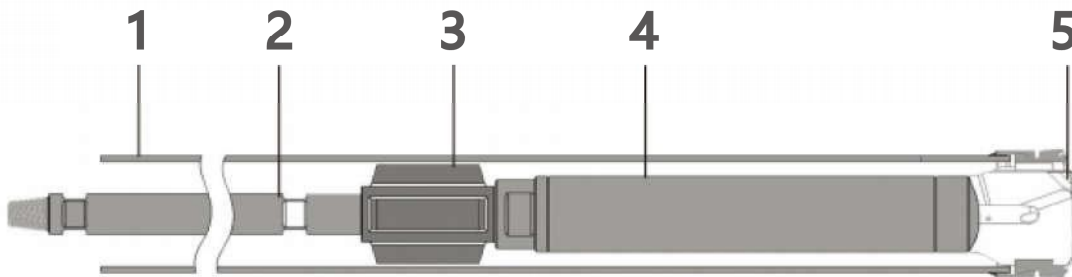

No	Items	Description
1	Casing Tube	a. Threaded casing tube, left turning thread b. Welded casing tube
2	Drill rod	Thread: API(REG/IF)/NC
3	Stabilizer	Thread of stabilizer is in keeping with drilling pipe
4	Hammer	Thread: API REG
5	Concentric Overburden Drilling System	Regard the specification forms as below

Application Range



Foundation

Because of its drilling smooth, good straightness of borehole and not effected by complex geological conditions such as gravel formation, it's suitable for application in foundation.

Anchoring

In general, the casing system is in the state of non-vertical when used in anchoring job, and the geological conditions are complex. Because the concentric casing system can drill at any angle, and without restriction of geological condition, so it can meet the practical requirements of anchoring project.

Bit Face



Shape A (Convex Face)



Shape B (Flat Face)



Shape C (Concave Face)

Concentric Casing System With Rings (Retrievable)

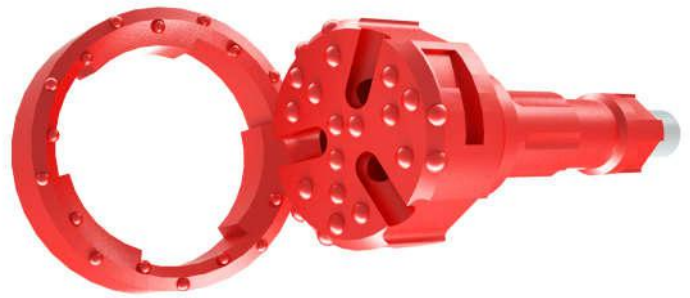
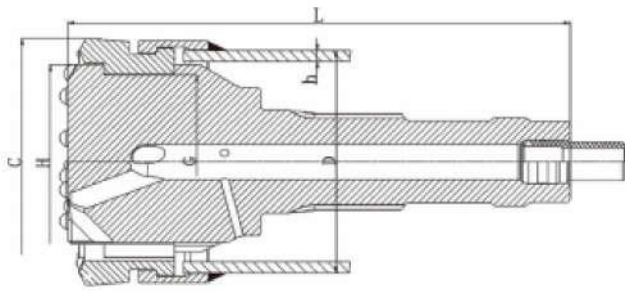

Part No.	D O.D of Casing Tube (mm)	I.D of Casing Tube (mm)	h Wall thickness of Casing Tube (mm)	H Max. O.D of Pilot Bit (mm)	C Reamer Dia. (mm)	G Max. O.D of Normal Bit (mm)	DTH Hammer/Top Hammer Type	Weight (kg)
Top Hammer Type								
MDC76/7RR-01	76	62	7	57	84	39	R32	3.2
MDC89/8RR-01	89	73	8	70	96	58	T38	5.8
MDC114/10RR-01	114	94	10	92	122	80	T45	7.5
MDC127/10RR-01	127	107	10	105	136	90	T45	10
MDC140/10RR-01	140	120	10	116	148	97	T45,T51	15
DTH Hammer Type								
MDC114/10RR-02	114	94	10	92	122	80	COP34/DHD3.5	10
MDC127/10RR-02	127	107	10	105	136	90	COP34/DHD3.5	16
MDC140/10RR-02	140	120	10	116	148	97	COP44/DHD340/SD4/QL40	21
MDC146/10RR-02	146	126	10	124	154	110	COP44/DHD340/SD4/QL40	22
MDC168/12.7RR-02	168	142.6	12.7	141	180	125	COP54/DHD350/SD5/QL50/M50	27
MDC178/12.7RR-02	178	152.6	12.7	150	186	135	COP54/DHD350/SD5/QL50/M50	32.5
MDC194/12.7RR-02	194	168.6	12.7	166	202	145	COP64/DHD360/SD6/QL60/M60	42.5
MDC219/12.7RR-02	219	193.6	12.7	191	228	170	COP64/DHD360/SD6/QL60/M60	58
MDC245/12.7RR-02	245	219.6	12.7	214	254	195	COP84/DHD380/SD8/QL80	78
MDC254/12.7RR-02	254	228.6	12.7	224	265	203	COP84/DHD380/SD8/QL80	84.5
MDC273/12.7RR-02	273	247.6	12.7	241	286	223	COP84/DHD380/SD8/QL80	100
MDC325/12.7RR-02	325	299.6	12.7	292	338	276	COP84/DHD380/SD8/QL80	135
MDC406/12.7RR-02	406	380.6	12.7	377	420	350	QL120/DHD112/SD12/NUMA120	280
MDC508/12.7RR-02	508	482.6	12.7	478	522	416	QL200/SD18/NUMA180	522
MDC560/12.7RR-02	560	534.6	12.7	528	575	475	QL200/SD18/NUMA180	620
MDC610/12.7RR-02	610	584.6	12.7	558	620	513	QL200/SD18/NUMA180	710

Concentric Casing System With Rings (Permanent)

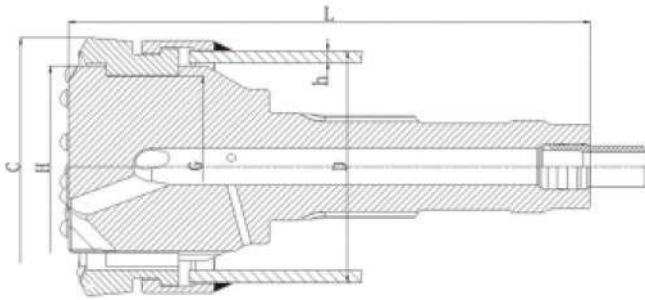

Part No	D		h	H	C	G		
	OD of Casing Tube (mm)	I.D of Casing Tube (mm)	Wall thickness of Casing Tube (mm)	Max. O.D of Pilot Bit (mm)	Reamer Dia.(mm)	Max. O.D of Normal Bit (mm)	DTH Hammer/Top Hammer Type	Weight (kg)
Top Hammer Type								
MDC76/7RP-01	76	62	7	57	88	39	R32	3.2
MDC89/8RP-01	89	73	8	70	100	58	T38	5.8
MDC114/10RP-01	114	94	10	92	126	84	T45	7.5
MDC127/10RP-01	127	107	10	105	142	93	T45	10
MDC140/10RP-01	140	120	10	116	161	97	T45,T51	15
DTH Hammer Type								
MDC114/10RP-02	114	94	10	94	126	84	COP34/DHD3.5	10
MDC127/10RP-02	127	107	10	05	142	93	COP34/DHD3.5	16
MDC140/10RP-02	140	120	10	116	161	97	COP44/DHD340/SD4/QL40	21
MDC146/10RP-02	146	126	10	124	165	110	COP44/DHD340/SD4/QL40	22
MDC168/12.7RP-02	168	142.6	12.7	141	188	127	COP54/DHD350/SD5/QL50/M50	27
MDC178/12.7RP-02	178	152.6	12.7	150	196	131	COP54/DHD350/SD5/QL50/M50	32.5
MDC194/12.7RP-02	194	168.6	12.7	166	214	145	COP64/DHD360/SD6/QL60/M60	42.5
MDC219/12.7RP-02	219	193.6	12.7	191	243	170	COP64/DHD360/SD6/QL60/M60	58
MDC245/12.7RP-02	245	219.6	12.7	214	268	195	COP84/DHD380/SD8/QL80	78
MDC254/12.7RP-02	254	228.6	12.7	224	276	203	COP84/DHD380/SD8/QL80	84.5
MDC273/12.7RP-02	273	247.6	12.7	241	298(305)	223	COP84/DHD380/SD8/QL80	100
MDC325/12.7RP-02	325	299.6	12.7	292	350	276	COP84/DHD380/SD8/QL80	135
MDC406/12.7RP-02	406	380.6	12.7	377	442	350	QL120/DHD112/SD12/NUMA120	280
MDC508/12.7RP-02	508	482.6	12.7	478	545	416	QL200/SD18/NUMA180	522
MDC560/12.7RP-02	560	534.6	12.7	528	595	475	QL200/SD18/NUMA180	620
MDC610/12.7RP-02	610	584.6	12.7	558	645	513	QL200/SD18/NUMA180	710

Concentric Casing System With Rings-Thread (Permanent)

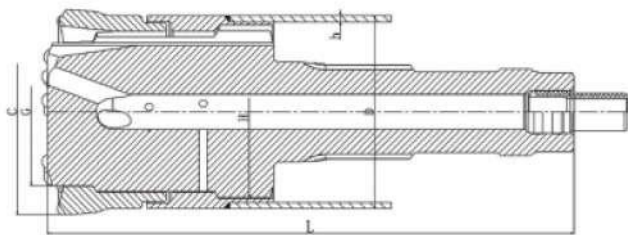

Part No.	D		h	H	C	G	DTH Hammer/Top Hammer Type	Weight (kg)
	O.D of Casing Tube (mm)	I.D of Casing Tube (mm)	Wall thickness of Casing Tube (mm)	Max. O.D of Pilot Bit (mm)	Reamer Dia. (mm)	Max. O.D of Normal Bit (mm)		
Top Hammer Type								
MDC76/8RPT-01	76	60	8	58	88	39	R32	2.5
MDC89/8RPT-01	89	73	8	71	100	52	T38	5.5
MDC114/10RPT-01	114	94	10	92	125	80	T45	9.5
MDC140/10RPT-01	140	120	10	118	158	96	T45,T51	10
DTH Hammer Type								
MDC108/6.5RPT-02	108	95	6.5	94	120	75	COP34/DHD3.5	10.1
MDC114/6.5RPT-02	114	101	6.5	99	126	82	COP34/DHD3.5	13.8
MDC127/9RPT-02	127	109	9	107	138	85	COP34/DHD3.5	18
MDC140/10RPT-02	140	120	10	118	154	96	COP44/DHD340/SD4/QL40	21
MDC146/10RPT-02	146	126	10	124	158	103	COP44/DHD340/SD4/QL40	23.5
MDC168/10RPT-02	168	148	10	153	188	125	COP54/DHD350/SD5/QL50/M50	27.5
MDC178/10RPT-02	178	158	10	157	196	140	COP54/DHD350/SD5/QL50/M50	42
MDC194/10RPT-02	194	174	10	172	214	148	COP64/DHD360/SD6/QL60/M60	57.5
MDC219/10.5RPT-02	219	198	10.5	196	243	170	COP64/DHD360/SD6/QL60/M60	75
MDC245/12.7RPT-02	245	219.6	12.7	218	260	185	COP84/DHD380/SD8/QL80	105
MDC273/12.7RPT-02	273	247.6	12.7	245	298	203	COP84/DHD380/SD8/QL80	122
MDC325/12.7RPT-02	325	299.6	12.7	294	350	255	COP84/DHD380/SD8/QL80	135
MDC406/12.7RPT-02	406	380.6	12.7	378	438	340	QL120/DHD112/SD12/NUMA120	420
MDC508/12.7RPT-02	508	482.6	12.7	478	538	445	SD18/NUMA180	522
MDC560/12.7RPT-02	560	534.6	12.7	521	580	495	SD18/NUMA180	608
MDC610/14.2RPT-02	610	581.6	14.2	574	630	514	QL200/SD18/NUMA180	703
MDC660/14.2RPT-02	660	631.6	14.2	618	680	590	QL200/SD18/NUMA180	788
MDC711/14.2RPT-02	711	682.6	14.2	674	731	606	QL200/SD18/NUMA180	934.5
MDC762/16RPT-02	762	730	16	724	782	669	NUMA240	1247
MDC813/16RPT-02	813	781	16	769	835	709	NUMA240	1380
MDC914/16RPT-02	914	882	16	851	935	818	NUMA240	1657
MDC1016/16RPT-02	1016	984	16	973	1040	913	NUMA240/QL300	2100
MDC1220/20RPT-02	1220	1180	20	1174	1250	1136	QL300	3270
MDC1550/20RPT-02	1550	1510	20	1504	1580	1464	MD36	5405

With Wings



Drilling through formations with loose, unconsolidated material always comes with problems such as the bore hole caving in or collapsing. How to avoid these problems?

With years of field practice and research, Maxdrill has developed its Concentric casing system with wings applicable for rock formation with silt, sand or small-sized pebbles. With its simple structure, convenient operation and reliable performance, this system can advance the casing easily for depth within 30 meters, and it is retrievable with long service life.

Application Range

Applicable for land surface covered, with loose material such as soil, clay, weathered rock sand.

Advantages

The locking pin through heat treatment, to extend service life.
Improve locking kit prevents the wings from falling off by dropping of the locking pin.

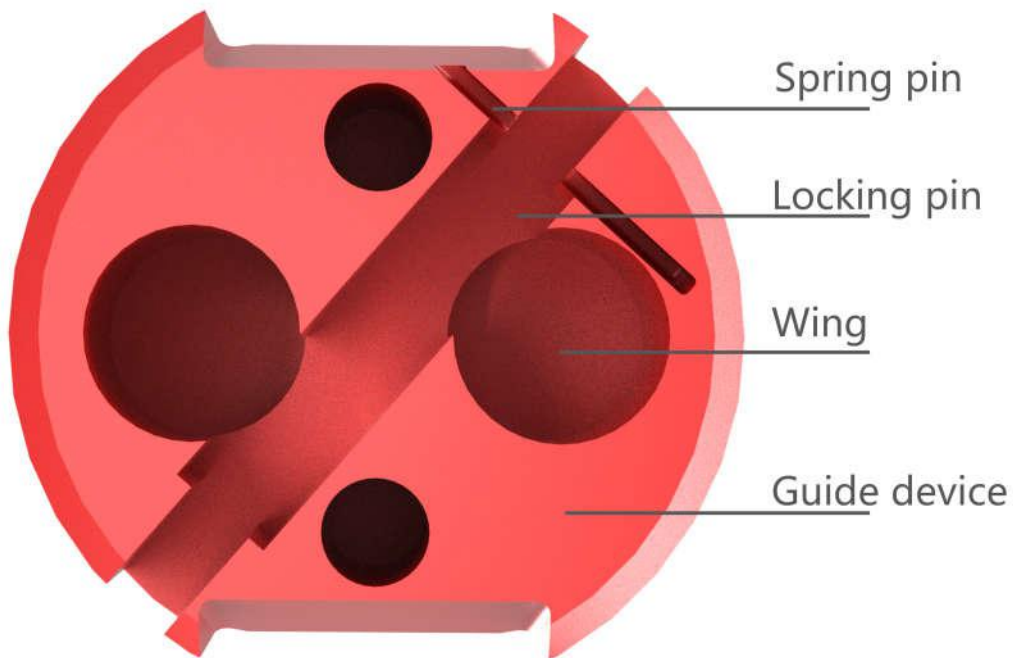

Component Parts

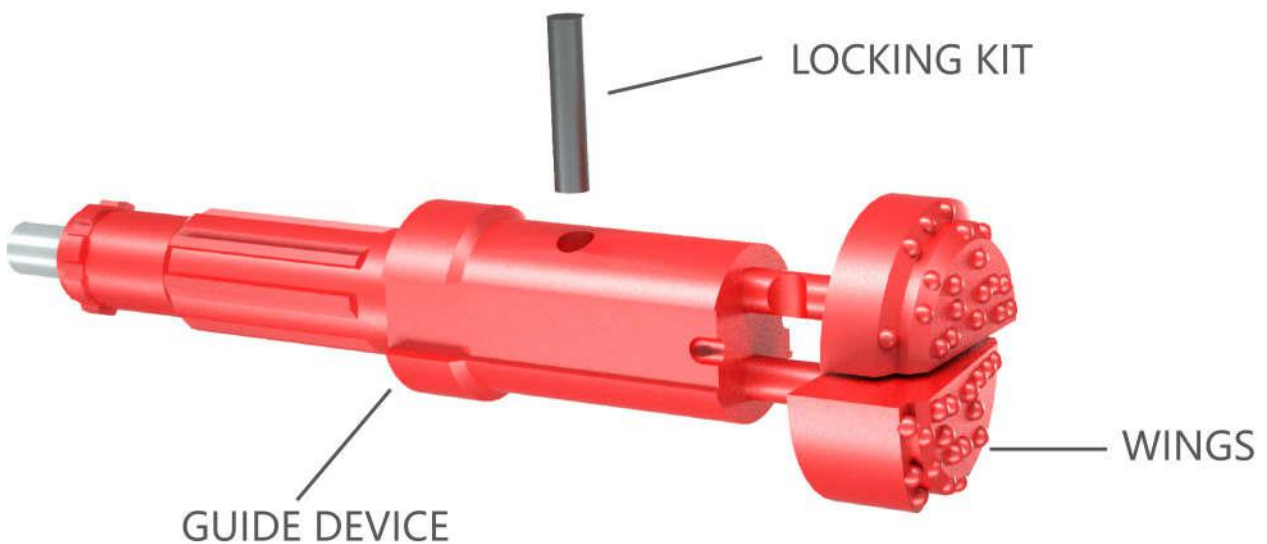

Related Parts List

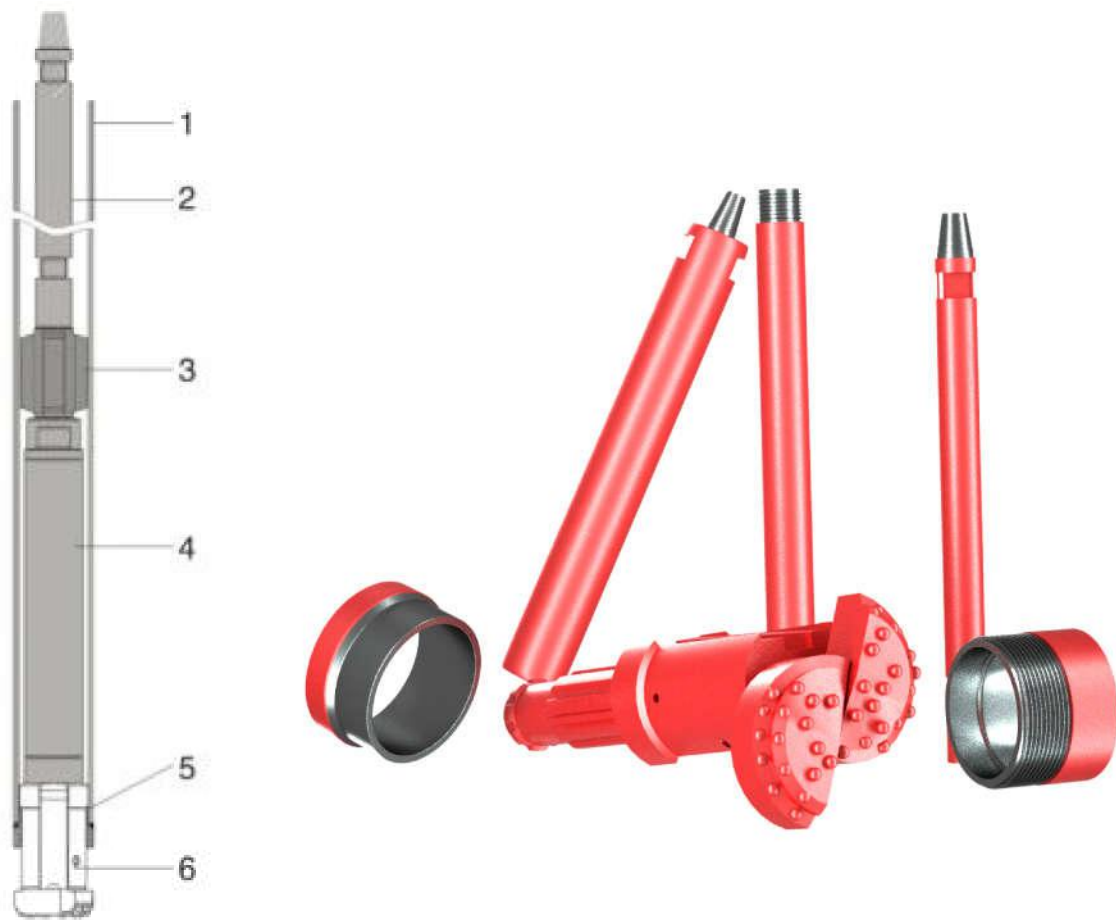

No	Items	Description
1	Casing Tube	a.Threaded casing tube, left hand b.Weldable casing tube
2	Drill Pipe	Thread: API(REG/IF)/NC
3	Stabilizer	Thread of stabilizer is with drilling rod
4	Hammer	Thread: API REG
5	Casing shoe	a.Threaded casing shoe, left hand b.Welded casing shoe
6	Wings system	Regard the specification forms as below

Operation Procedure

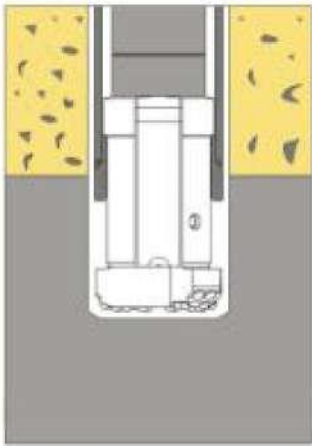

When drilling starts, the system drives the casing shoe and casing tube down.

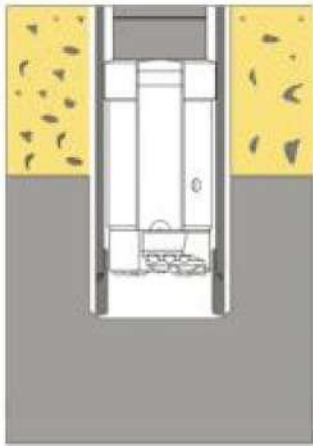

When Drilling in overburden formation is finished, reverse rotation and pull the drill string out from the casing tube.

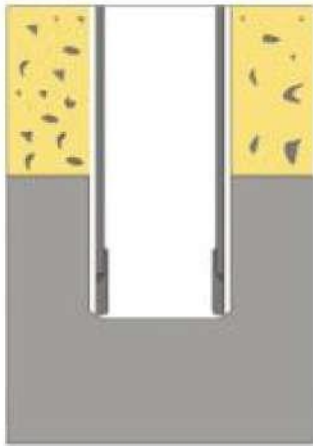

Pour in concrete or continue to next step.

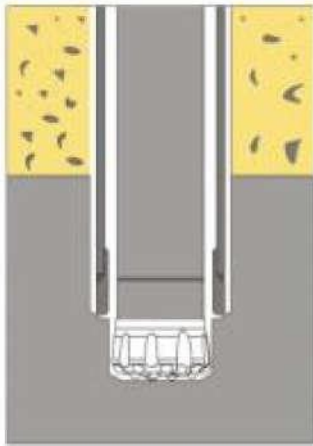

Use normal tools to drill to the desired depth.

Advantages

The material of tool joint is better than casing tube and through heat treatment to ensure connection reliability.

Casing shoe through heat treatment ensures long service life.

Application Range



Water well



Foundation



Anchoring

Concentric Casing System With Wings

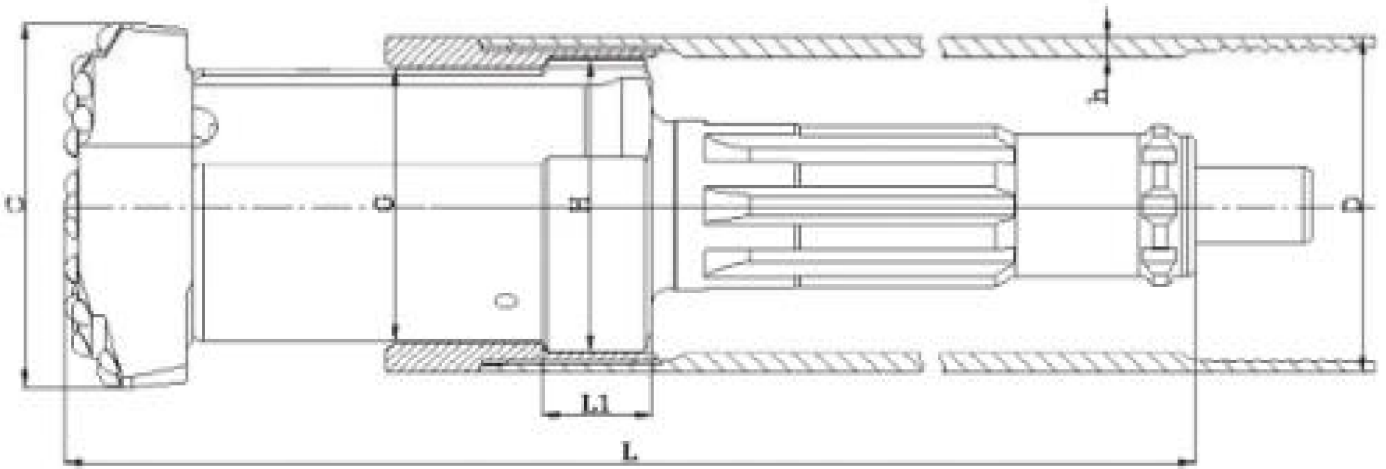

Part No.	D	I.D of casing tube (mm)	h	H	C	G	Qty of the wing	Hammer type	Weight
MDC114/6.5W-02	114	101	6.5	99	125	90	2	DHD3.5/COP34	15
MDC146/10W-02	146	126	10	124	157	117	2	COP44/DHD340/SD4/QL40	20.3
MDC168/10W-02	168	148	10	146	180	136	2	COP54/DHD350/SD5/QL50	33.4
MDC178/10W-02	178	158	10	154	195	142	2	COP54/DHD350/SD5/QL50	38.8
MDC194/10W-02	194	174	10	172	206	160	2	COP54/DHD350/SD5/QL50	46.4

With Blocks

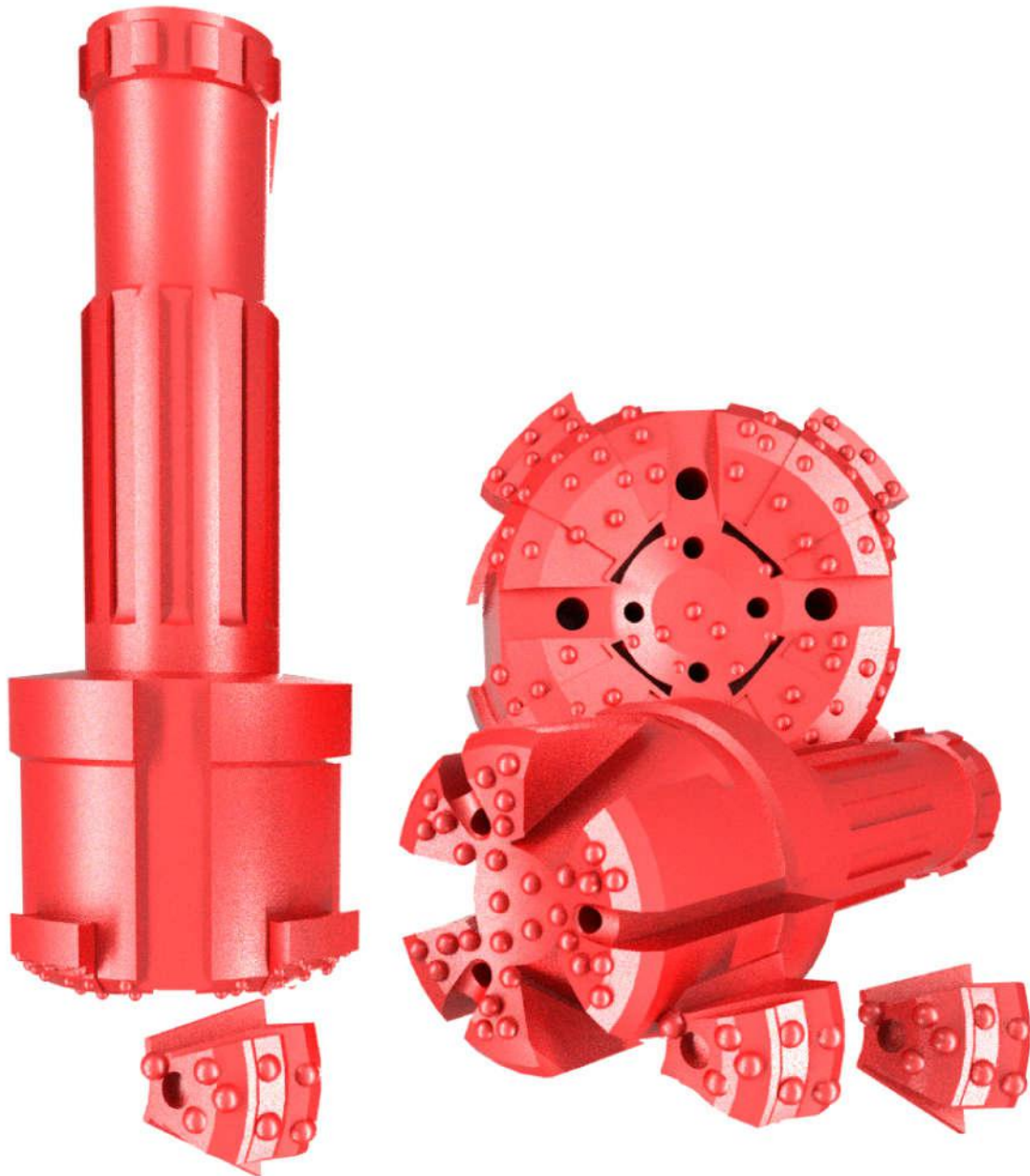

Drilling through formations with loose, unconsolidated material always comes with problems such as the bore hole caving in or collapsing. How to avoid these problems?

With years of field practice and research, Maxdrill has developed its Concentric casing system with blocks applicable for foundation piling with backfill and pebble formations and casing depth within 40 meters.

Component Parts



Operation Procedure

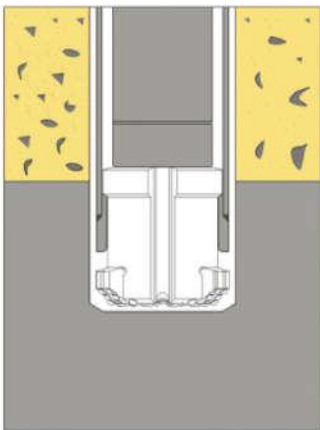

When drilling starts, the pilot bit drives the casing shoe and casing tube.

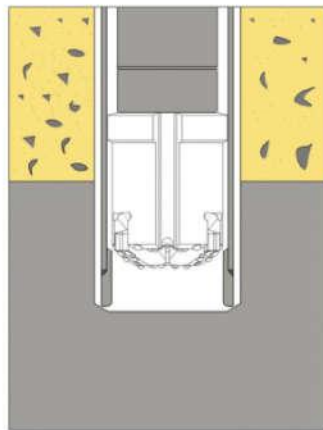

When reaching the bedrock, reverse rotation of the tools and pull the pilot bit out from the hole.

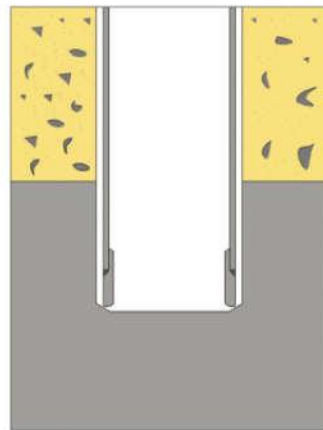

Pour in concrete or move to the next construction procedure.

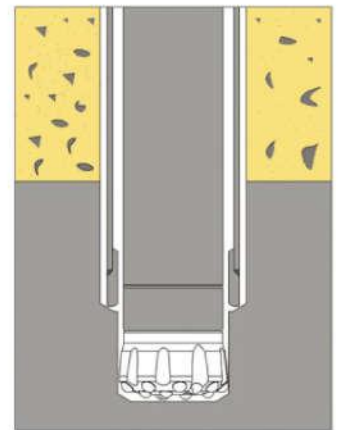

Use conventional tools to drill to the desired depth.

Advantage of Design

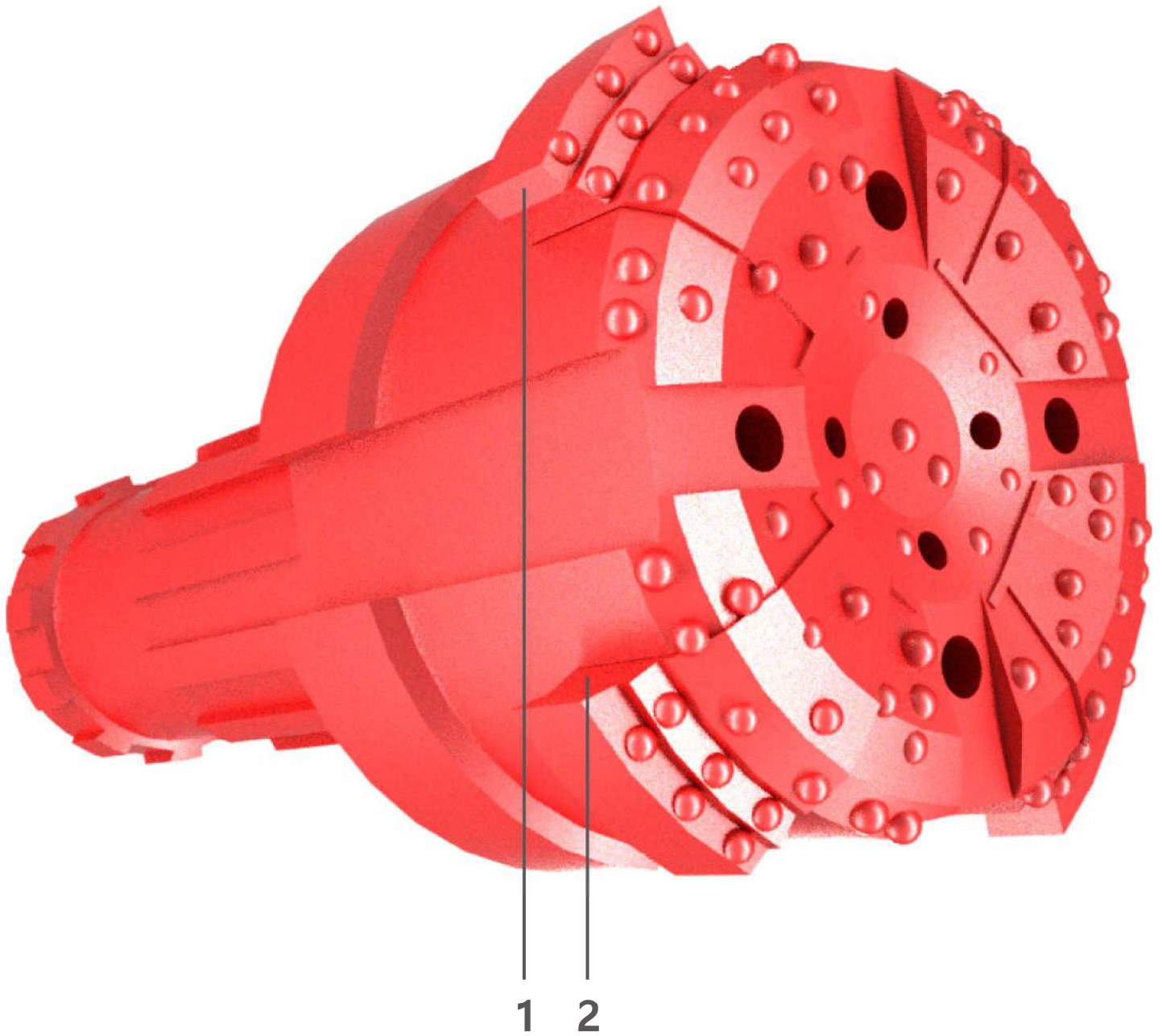

1. Large bevel along block's rotation direction to increase drilling stability.
2. Bevel on block's back to guide pulling of drill string for easy retrieval.

Related Parts List

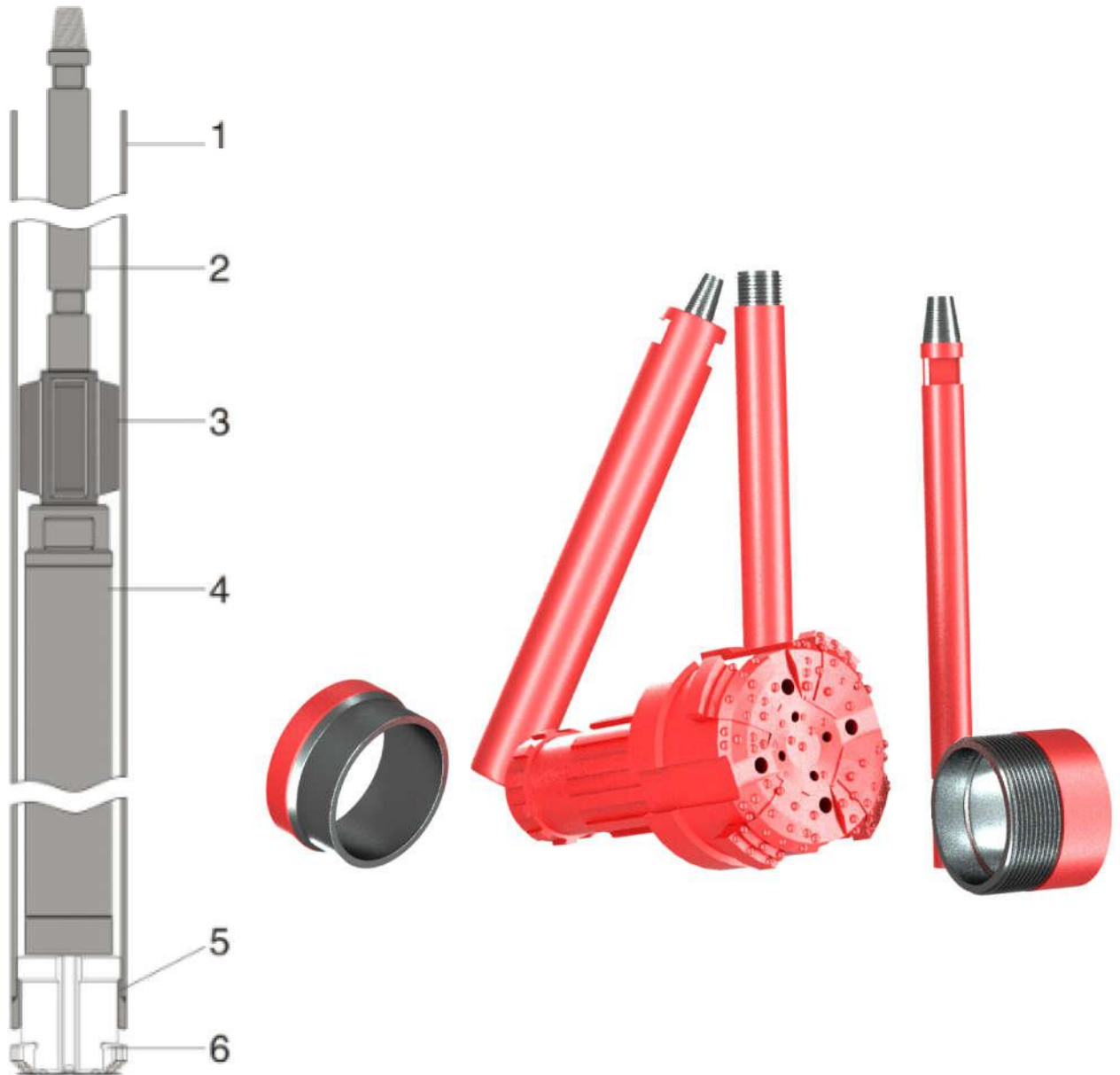

No	Items	Description
1	Casing Tube	a. Casing tube connected by left-hand threaded. b. Casing tube connected by welding
2	Drill Rod	Thread: API(REG/IF)/NC
3	Stabilizer	Thread of stabilizer is the same as drill rod
4	Hammer	Thread: API REG
5	Casing shoe	a. Thread casing shoe, left hand b. Welded casing shoe
6	Blocks system	Regard the specification forms as below

Strengthening Measures For Manufacturing

1. The material of tool joint is better than casing tube and through heat treatment to ensure the reliability.
2. Casing shoe through heat treatment ensures long service life.
3. Blocks and locking system through strengthening treatment for good comprehensive performance.

Application Range



Foundation Pile



Anchoring

Concentric Casing System With Blocks

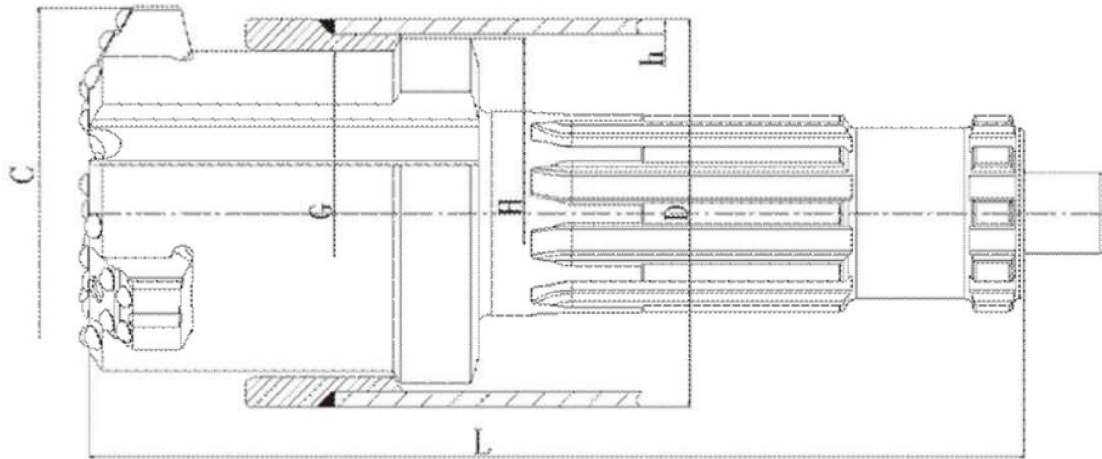

Part No.	D	h	H	C	G	Blocks	Hammer type	Weight (Kg)	
	O.D of casing tube (mm)	I.D of casing tube (mm)	Wall thickness of casing (mm)	Guide device max.Dia (mm)	Reamed Dia. (mm)	Max.O.D of Normal bit (mm)			
MDC219/10B-02	219	199	10	197	234	185	3	COP64/DHD360/SD6/QL60/M60	61
MDC245/10B-02	245	225	10	222	260	210	3	COP84/DHD380/SD8/QL80	88
MDC273/10B-02	273	253	10	251	305	240	3	COP84/DHD380/SD8/QL80	96.5
MDC325/10B-02	325	305	10	302	350	282	3	COP84/DHD380/SD8/QL80	115
MDC355/10B-02	355	325	10	322	380	305	3	DHD112	214
MDC406/12B-02	406	382	12	380	432	365	4	DHD112	254
MDC480/12.7B-02	480	454.6	12.7	450	505	432	4	MD14	415
MDC508/12.7B-02	508	482.6	12.7	479	534	461	4	NUMA180	630
MDC560/12.7B-02	560	534.6	12.7	530	590	510	4	NUMA180	730
MDC610/12.7B-02	610	584.6	12.7	582	639	553	4	NUMA180	895
MDC660/16B-02	660	628	16	625	690	596	4	NUMA180	946
MDC711/16B-02	711	679	16	675	741	645	4	NUMA180	1010
MDC762/16B-02	762	730	16	726	792	694	4	NUMA240	1595
MDC813/16B-02	813	781	16	776	845	744	6	NUMA240	2436
MDC914/16B-02	914	882	16	878	946	846	6	NUMA240/QL300	2756
MDC1016/16B-02	1016	984	16	980	1050	948	6	NUMA240/QL300	3076

Casing Tube

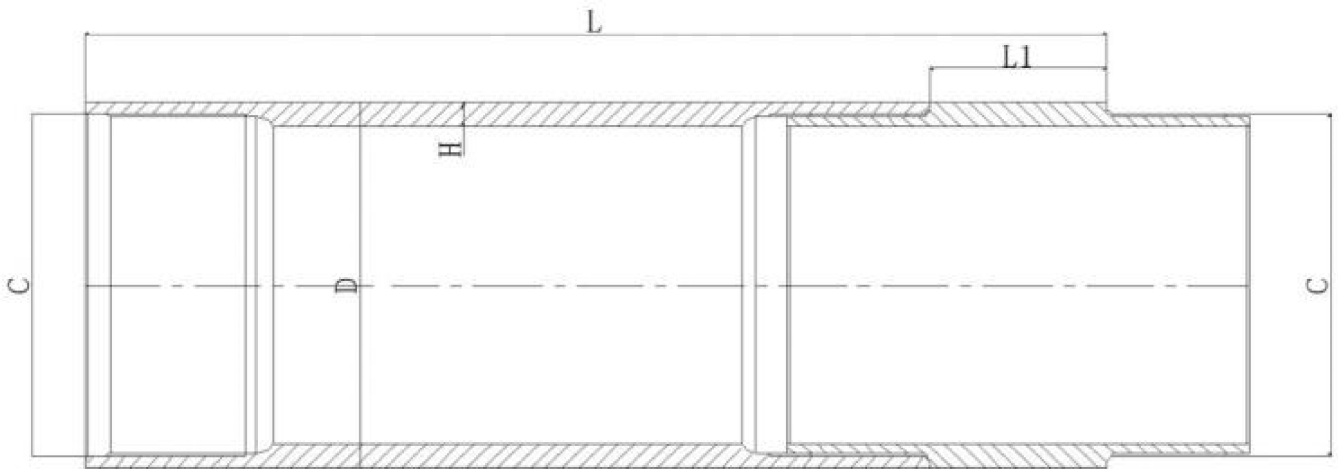

C: thread of the casing tube L: length of the casing tube L1: length of the tool joint
 D: O.D of the casing tube H: Thickness of the casing tube

Casing tube with tool joint

O.D. of casing shoe	Thickness (h)	Item	Thread(C)	Direction of rotation	Length (L)	Weight	Part No.
108	7	108 Casing Tube with tools joint	Square thread	Left	1500	27.1	M108/7-15-S
114	6.5	114Casing Tube with tools joint	Square thread	Left	1500	31	M114/6.5-15-S
127	9.5	127 Casing Tube with tools joint	Circular-arc Thread	Left	1500	43.7	M127/9.5-15-C
127	6.5	127 Casing Tube with tools joint	Circular-arc Thread	Left	1500	35	M127/6.5-15-C
146	10	146Casing tube with tools joint	Circular-arc Thread	Left	1500	53.7	M146/10-15-C
168	10	168Casing tube with tools joint	Circular-arc Thread	Left	1500	62.4	M168/10-15-C
178	9	178Casing tube with tools joint	Circular-arc Thread	Left	1500	61.8	M178/9-15-C
194	10	194Casing tube with tools joint	Circular-arc Thread	Left	1500	73	M194/10-15-C
219	10	219Casing tube with tools joint	Circular-arc Thread	Left	1500	85.7	M219/10-15-C
273	10	273Casing tube with tools joint	Circular-arc Thread	Left	1500	107.7	M273/10-15-C
325	12	325Casing tube with tools joint	Circular-arc Thread	Left	1500	154.7	M325/12-15-C

Casing tube					Tool Joint			
Model (D)	Thickness (h)	Item	Weight	Part No.	Item	Length (L)	Weight	Part No.
108	7	108Casing tube	24.6	M108/7-15-S-01	108 Tool joint	80	2.5	M108/7-15-S-02
127	9.5	127Casing tube	38.8	M127/9.5-15-C-01	127 Tool joint	90	4.9	M127/9.5-15-C-02
127	6.5	127Casing tube	30.1	M127/6.5-15-C-01	127 Tool joint	90	4.9	M127/6.5-15-C-02
146	10	146Casing tube	47.3	M146/10-15-C-01	146Tool joint	80	6.4	M146/10-15-C-02
168	10	168Casing tube	55	M168/10-15-C-01	168Tool joint	80	7.4	M168/10-15-C-02
178	9	178Casing tube	52.9	M178/9-15-C-01	178Tool joint	100	8.9	M178/9-15-C-02
194	10	194Casing tube	64	M194/10-15-C-01	194Tool joint	100	9	M194/10-15-C-02
219	10	219Casing tube	72.7	M219/10-15-C-01	219 Tool Joint	100	13	M219/10-15-C-02
273	10	273Casing tube	91.5	M273/10-15-C-01	273 Tool Joint	100	16.2	M273/10-15-C-02
325	12	194Casing tube	130.7	M325/12-15-C-01	325 Tool Joint	100	24	M325/12-15-C-02

Remark: Casing tubes above can be without tool joint.



Casing Shoe Threaded Model

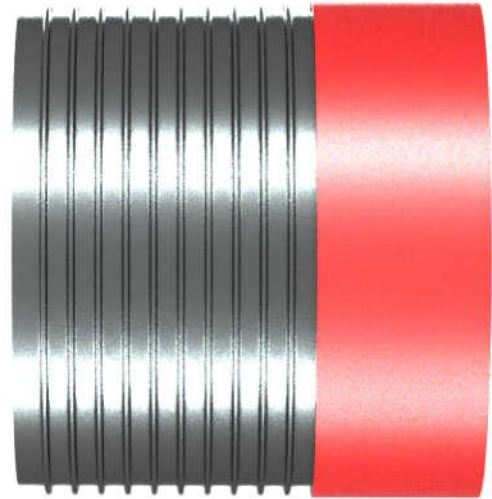
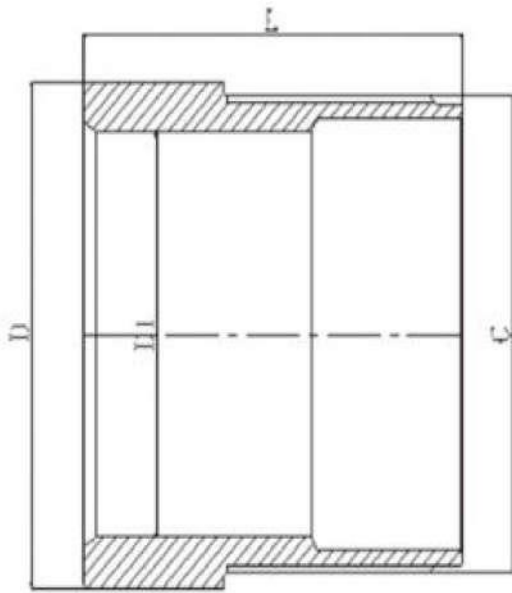

Part No.	D O.D of casing shoe (mm)	D1 Min.I.D of casing shoe (mm)	h Thickness (mm)	Thread type	Direction of rotation	Weight (kg)
MST114/6.5-S	114	91	6.5	Square thread	Left	3
MST127/9.5-C	127	100	9.5	Circular-arc Thread	Left	3.3
MST146/10-C	146	117	10	Circular-arc Thread	Left	4.4
MST168/10-C	168	138	10	Circular-arc Thread	Left	6.1
MST178/10-C	178	148	10	Circular-arc Thread	Left	7.5
MST194/10-C	194	162	10	Circular-arc Thread	Left	6.8
MST219/10-C	219	186	10	Circular-arc Thread	Left	12.8
MST273/10-C	273	241	10	Circular-arc Thread	Left	15
MST325/10-C	325	282	10	Circular-arc Thread	Left	18

Other casing shoes are available upon request

Casing Shoe Welding Model

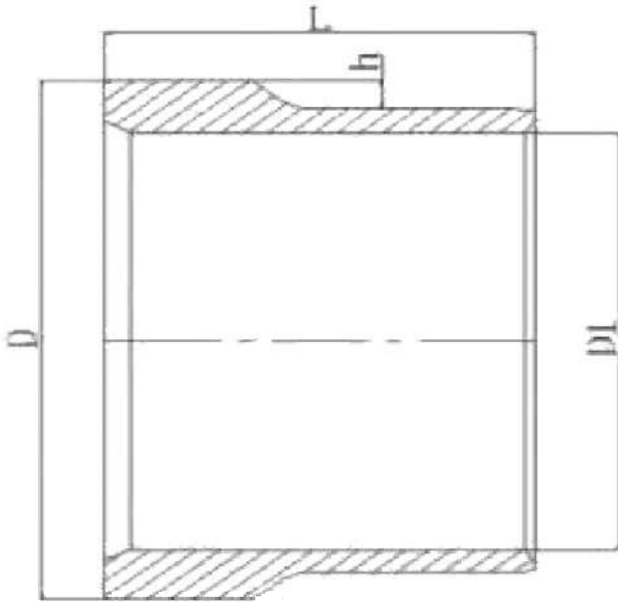

	D	D1	h	
Part No.	O.D of casing shoe (mm)	Min.I.D of casing shoe (mm)	Thickness (mm)	Weight (kg)
MSW114/6.5	114	91	6.5	2.5
MSW127/9.5	127	100	9.5	3
MSW146/10	146	117	10	3.8
MSW168/10	168	138	10	5
MSW178/10	178	148	10	6
MSW194/10	194	162	10	5.8
MSW219/10	219	186	10	10
MSW273/10	273	241	10	13.5
MSW325/10	325	282	10	16

Other casing shoes are available upon request

Drill Pipe

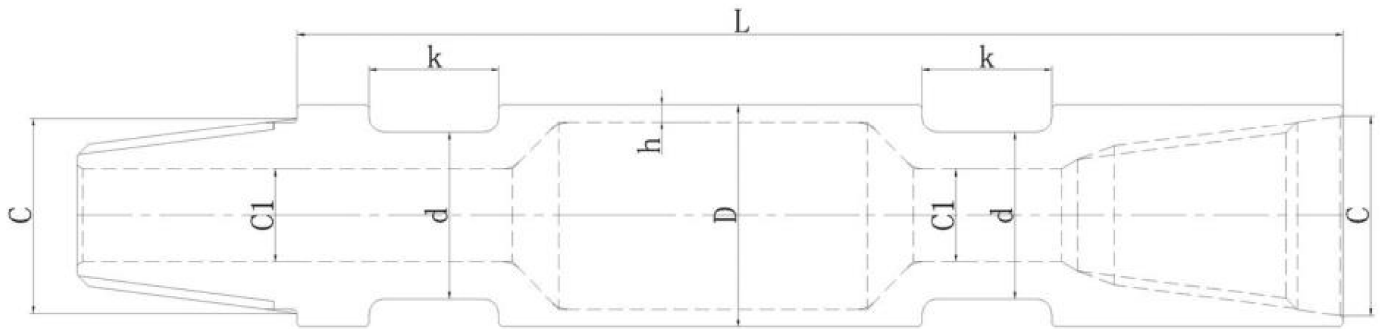

Model(D)	Wall thickness (h)	Thread(C)	I.D./C1	Wrench d	Flat size k	Length/L	Weight	Part No.
76(3)	6.5	API 2 3/8REG	32	57	45	3000	40	M76/6.5-30-01
	8.5	API 2 3/8REG	32	57	45	3000	48	M76/8.5-30-01
89(3 1/2)	6.5	API 2 3/8REG	32	70	45	3000	48	M89/6.5-30-01
	8.5	API 2 3/8REG	32	70	45	3000	58	M89/8.5-30-01
	6.5	NC26	40	70	45	3000	48	M89/6.5-30-04
	8.5	NC26	40	70	45	3000	58	M89/8.5-30-04
102(4)	6.5	API 3 1/2REG	45	83	51	3000	56	M102/6.5-30-02
	8.5	API 3 1/2REG	45	83	51	3000	67	M102/8.5-30-02
	6.5	NC31	45	83	51	3000	56	M102/6.5-30-05
	8.5	NC31	45	83	51	3000	67	M102/8.5-30-05

Model(D)	Wall thickness (h)	Thread(C)	I.D./C1	Wrench d	Flat size k	Length/L	Weight	Part No.
114(4 1/2)	6.5	API 3 1/2REG	45	95	51	3000	63	M114/6.5-30-02
	8.5	API 3 1/2REG	45	95	51	3000	76	M114/8.5-30-02
	6.5	NC35	60	95	51	3000	63	M114/6.5-30-06
	8.5	NC35	60	95	51	3000	76	M114/8.5-30-06
127(5)	8.5	API3 1/2REG	45	108	51	3000	86	M127/8.5-30-02
127(5)	8.5	NC38	60	108	51	3000	86	M127/8.5-30-07
133 (5 1/4")	10	API3 1/2REG	45	114	51	3000	102	M133/10-30-02
140 (5 1/2")	9.2	API3 1/2REG	45	121	51	3000	101	M140/9.2-30-02
146 (5 3/4")	10	API4 1/2REG	60	127	55	3000	113	M146/10-30-03
152 (6")	8.5	API4 1/2REG	60	133	55	3000	105	M152/8.5-30-03
168 (6 5/8")	10	NC50	60	149	55	3000	132	M168/10-30-08
178 (7")	10	API4 1/2REG	60	159	55	3000	140	M178/10-30-03

The other specification can be produced according to your requirements



Double Wall Drill Pipe

Model	Adaptor	Length	Weight	Part No.
426	273 hex	4M	1070	MDW426/10-40
450	273 hex	4M	1093	MDW450/12-40
508	273 hex	4M	1146	MDW508/10-40
610	273 hex	4M	1241	MDW610/10-40
711	320 hex	6M	1943	MDW711/10-60
813	320 hex	6M	2087	MDW813/10-60
914	320 hex	6M	2230	MDW913/10-60



MAXDRILL ROCK TOOLS CO.,LTD

 Add:9/F, Fuzhong International Plaza, No.72 Xinhua Road, Nanming District, GuiYang, China

 Factory in Guizhou :Er Guan Ba Industry Park, Jiuchang Town, Xiuwen County, Guizhou Province, China

 Tel:86-851-88639106 Fax:86-851-88639108

 E-mail:office@kemaico.com info@kemaico.com

 Web:www.maxdrillrocktools.com www.maxdrill.com.cn